

Only 3,8 W
21 dB(A)



NEW
Smart
Smart IR



Use

- Smart exhaust fan with stylish design for enhanced comfort in bathrooms, shower rooms, kitchens.

Features

- Intelligent electronics and integrated functions for the ideal microclimate.
- High air capacity up to 133 m³/h and silent operation due to specially designed motor and aerodynamic profiled impeller.
- High-efficient DC motor with low energy demand of only 3.8 W and reliable non-stop operation above 50 000 hours.
- Impulse-type power supply unit with a wide power supply range from 100 to 240 V, 50-60 Hz provides uninterrupted operation in electrical grids with versatile power supply standards.
- The fan has automatic power shutoff function in case of the motor jam.
- Low noise level due to specially elaborated fixation of the motor and the impeller on a vibration absorbing mount.
- The built-in slide switch makes it easy to disconnect the fan from power mains for safe operation.
- Ultrathin casing with 28 mm thickness.
- Versatile mounting – vertical or horizontal installation.
- Function setup and fan control from a remote controller.

- Replaceable connecting piece for connection to Ø100 or 125 mm air ducts.

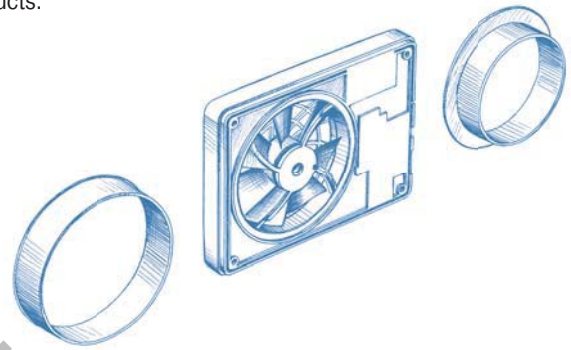

- Easy detachable motor and impeller block requires no tools and provides comfortable servicing.

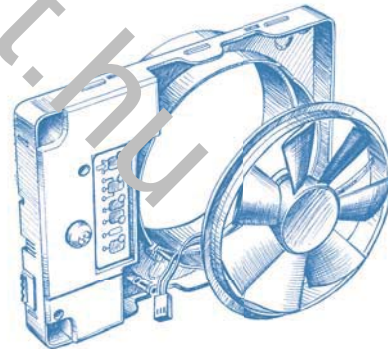

- Multifunctional control panel with LED's:

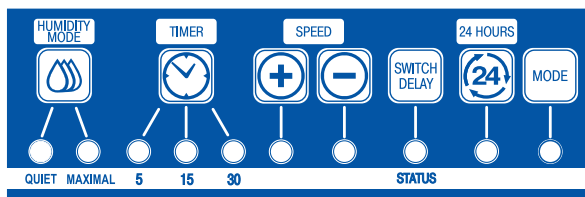

Smart

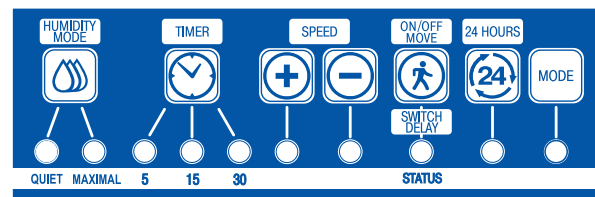

Smart IR

Modes and functions

- The fan is developed with respect to the latest intelligent ventilation technologies:



INTELLIGENT HUMIDITY SENSOR

- The fan is equipped with an intelligent humidity sensor for automatic control of natural indoor climate.

QUIET – the balanced humidity extraction mode that provides sufficient air capacity (up to 83 m³/h) combined with silent operation. This mode is recommended for small bathrooms.

MAXIMAL – excessive humidity extraction mode with maximum air capacity up to 133 m³/h. This mode is recommended to the bathrooms above 6 m².



TIMER

- The fan is equipped with three various types of timers for the most comfortable microclimate:

HUMIDITY TIMER – adjustment of the operation time of the fan for total humidity removal after stabilization of its level, adjustable for 30, 45, 60 min.

TURN-OFF DELAY TIMER – after activation of the IR motion sensor or the external switch the fan continues operating within 5, 15 or 30 min and then reverts to previous operation mode.

TURN-ON DELAY TIMER – if you have to visit your bathroom frequently and briefly, adjust the turn-on delay function to avoid unnecessary switching of the fan.

The fan switches to higher speed in 0, 2 or 5 minutes after the humidity level increase or activation of the IR motion sensor.



24 HOURS

- The fan runs with low speed to ensure minimum air exchange in the room. After humidity change, the fan switches to MAXIMAL (by default) or QUIET mode. After the signal from the IR-Sensor or an external switch the fan will turn to QUIET mode.



INTERVAL VENTILATION

- Integrated function of the automatic room ventilation. Each 15 hours the fan is switched on for 2 hours to ventilate the premise with the air capacity 83/72 m³/h (Ø125 / Ø100).



SMOOTH SPEED CONTROL

- The fan has an integrated smooth speed control function adjustable in 10 speeds:

– for **QUIET** mode from 40/33 to 83/72 m³/h (Ø125/100);
 – for **MAXIMAL** mode from 83/72 to 133/106 m³/h (Ø125/100).



IR MOTION SENSOR (for SMART IR)

- Automatic switching of the fan on in QUIET mode after the IR motion sensor is activated. The sensor reach area is from 1 to 4 m and the viewing angle 100°.

Overall and mounting dimensions

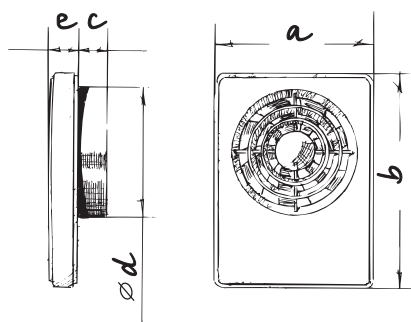

Type	Dimensions [mm]				
	a	b	c	d	e
SMART	155.5	209	28	99/124	28
SMART IR	155.5	209	28	99/124	28

Technical data

Connecting piece	Mode	Maximum air capacity [m ³ /h]	Noise level [dB(A) 3m]	Air capacity, factory settings [m ³ /h]	Control range [m ³ /h]
100	24 hours	33	17	33	-
	Quiet	72	22	72	33...72
	Maximal	106	31	82	72...106
125	24 hours	40	17	40	-
	Quiet	83	21	83	40...83
	Maximal	133	32	97	83...133

