

REVERSIBLE HEAT AND ENERGY RECOVERY VENTILATOR

SOLO Series

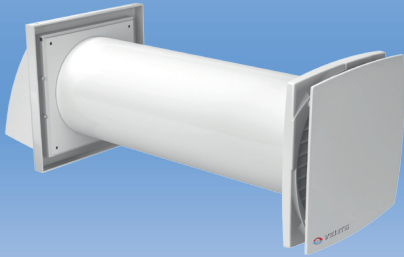

Wall ventilator with heat and energy recovery

Applications

- Supply clean fresh air to the premises
- Remove stale extract air from the premise
- Clean the air of dust and insects
- Prevent penetration of excessive humidity and appearance of mould
- Protect against outdoor noise
- Recover heat and provide humidity balance inside
- Reduce the heating costs in winter and air conditioning costs in summer
- Low energy demand

Operation logic

- Energy is recovered due to reversing operation of the ventilator, which consists of two cycles:

CYCLE I. As warm stale extract air flows through the ceramic heat exchanger, it heats up and moisturizes the heat exchanger. In 70 seconds as the ceramic heat exchanger gets warmed the ventilator automatically switches to Air Supply mode.

CYCLE II. Fresh, cold intake air from outside flows through the ceramic heat exchanger, absorbs accumulated moisture and is heated to the room temperature. In 70 seconds as the heat exchanger gets cooled down, the ventilator switches to Air Extract mode and the cycle is renewed.

- The Air Supply and the Air Extract modes are switched every 70 seconds.

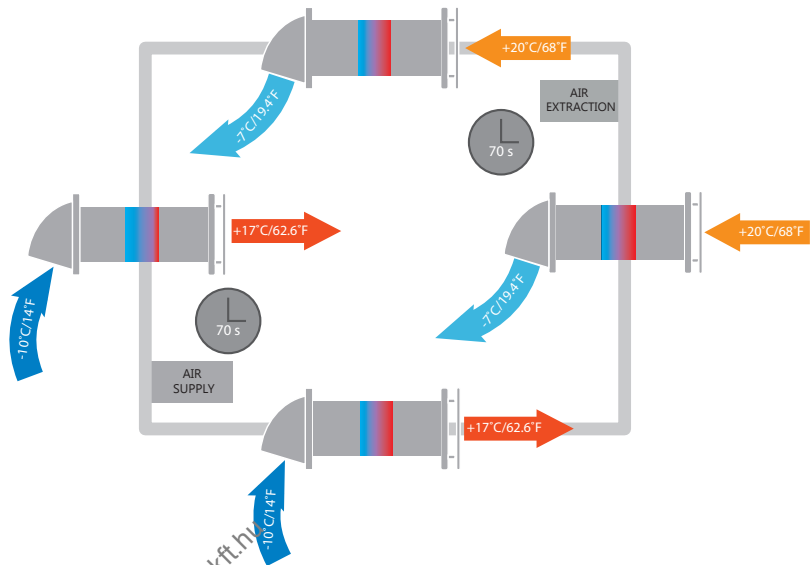

Design

Fan

Air is supplied or extracted by a reversible axial fan with EC motor. Due to EC technology the fan is distinguished with low energy demand. The motor has overheating protection and ball bearings for longer service life.

Air filters

Two built-in filters with total filter class G3 are used to clean supply and extract air flows. The filters ensure fresh air cleaning of dust and insects and prevent the ventilator parts from soiling. The filters are cleaned either with a vacuum cleaner or flushed with water.

Energy heat exchanger

The high-technology energy heat exchanger is used for extract air heat energy recovery and supply air heating.

The Solo RA1-35A-9 R is equipped with the aluminium energy heat exchanger with recovery efficiency up to 75 %.

The Solo RA1-35-9 R is equipped with the ceramic energy heat exchanger with recovery efficiency up to 85 %.

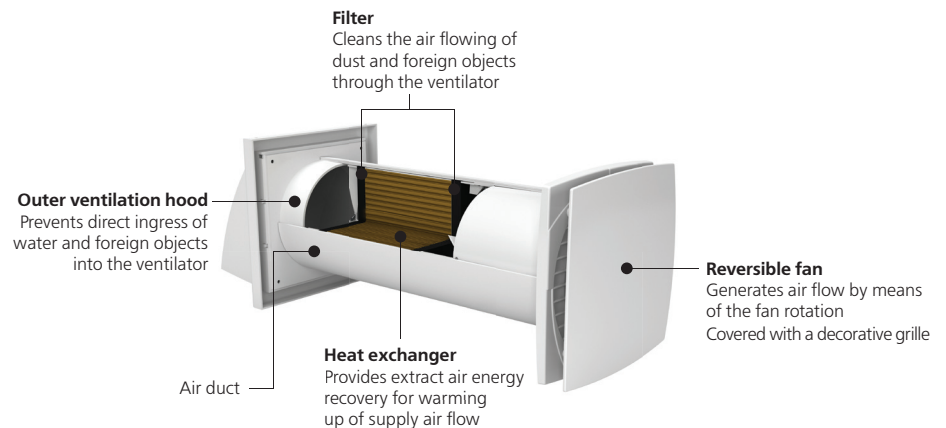

Technical data

	Solo RA1-35A-9 R		Solo RA1-35-9 R	
Speed	1	2	1	2
Voltage [V / 50-60 Hz]	230			
Power [W]	1.43	1.92	1.36	1.89
Current [A]	0.032	0.034	0.031	0.034
Maximum air capacity [m ³ /h]	23	35	30	46
Sound pressure level at 3 m distance [dB(A)]	27	32	27	32
Maximum transported air temperature [°C]	from -15 up to +50			
Heat recovery efficiency [%]	≤75		≤85	
Heat exchanger type	Aluminum		Ceramic	
Energy efficiency class	A		A	
Ingress protection rating	IP 24			

Overall dimensions

Dimensions, mm					
Ø D	B	B1	L	L1	L2
103	150	153	305-380	30	84

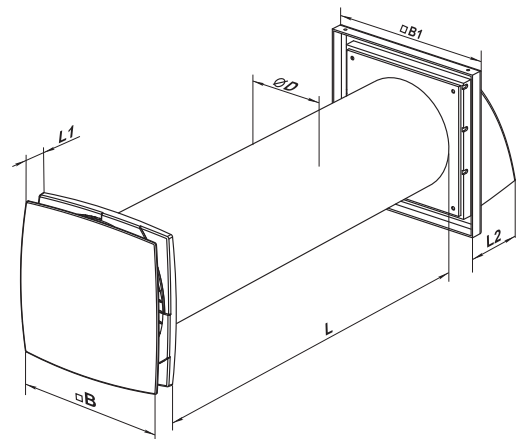

Control

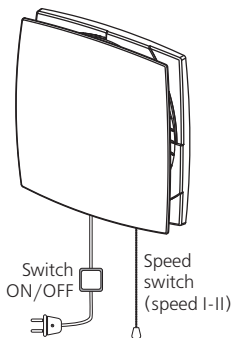

mepokerkft.hu

Mounting example

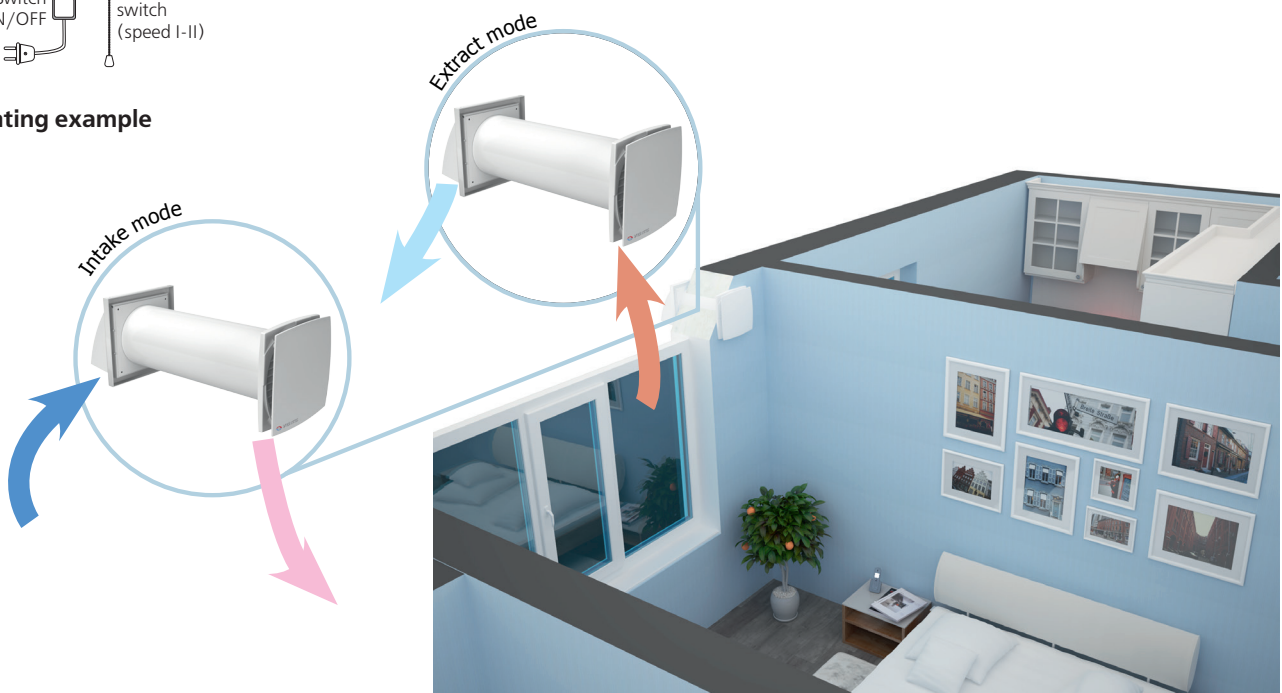

Certificates



The fans meet the applicable safety and electromagnetic compatibility standards.