

Series
VENTS VUT/VUE VB EC



Air handling units in heat- and sound-insulated casing.
Air flow up to **690 m³/h**.
Heat recovery efficiency up to **93 %**

■ **Description**

The air-handling units are the fully featured ventilation units with heat recovery for air filtration, fresh air supply and stale air extract. During operation the extract air heat is transferred to the supply air stream by the highly efficient plate heat exchanger.

The units are designed for energy efficient ventilation of cottages and flats and are compatible with round air ducts (Ø 125, 160 and 200 mm).

■ **Casing**

Made of high-quality polymer coated steel, internally filled with 20, 25, 30 or 40 mm (depending on the unit model) mineral wool layer for heat and sound insulation.

■ **Filter**

Supply and exhaust air is purified in panel filters with filtering class G4 and F7, respectively. Filters with G3 filtering class are used for supply and exhaust air purification in the **VUT/VUE 200 VB EC** units.

Supply air in the **VUT/VUE 250 VB EC** units is purified by the G4 and F7 filters. Exhaust air is purified by the G4 filters.

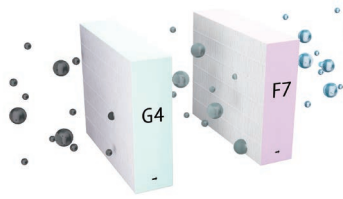

■ **Fans**

The units are equipped with high-efficient EC motors with an external rotor and a centrifugal impeller with backward curved blades. These state-of-the-art motors are the most advanced solution in energy efficiency today.

EC motors are characterised with high performance and optimum control across the entire speed range. In addition to that, the efficiency of the electronically commutated motor reaches very impressive levels of up to 90 %.

■ **Heat exchanger**

The **VUT V(B) EC** units are equipped with a counter-flow polystyrene heat exchanger. In the cold season the extract air heat is captured and transferred to the supply air stream which reduces the ventilation-generated heat losses. This can lead to formation of condensate that is collected in a special drain pan and discharged into the sewage system.

In the warm season the ambient air heat is transferred to the exhaust air stream. This allows for a considerable reduction of the supply air temperature which, in turn, reduces the air conditioning load.

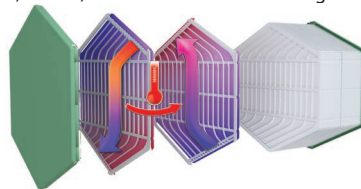

The **VUE V(B) EC** units are equipped with a counterflow enthalpy heat exchanger. In the cold season the extract air heat and moisture are transferred to the supply air stream through the enthalpy heat exchanger reducing the heat losses from ventilation. The ambient air heat and moisture are transferred to the exhaust air stream through the enthalpy heat exchanger in the warm season.

This allows for a considerable reduction of the supply air temperature and humidity which, in turn, reduces the air conditioning load.

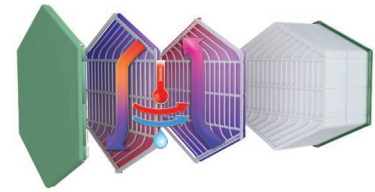

■ **Bypass**

The **VUT/VUE VB EC** units are equipped with a bypass for summer ventilation (air cooling by the cool air from outside).

■ **Automation**

The **VUT/VUE V(B) EC A21** are equipped with a built-in automation system. The A21 controller allows integrating the unit into the Smart Home system or BMS (Building Management Systems). The remote control panel is not included in the delivery set (available separately). To control the unit via Wi-Fi, download the VENTS AHU mobile app.

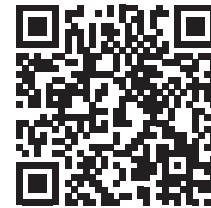

Google play



Download on the App Store



The **VUT/VUE V(B) EC A14** units have an integrated control system with a wall-mounted control panel A14 with a LED indication.

The **VUT 200 V(B) EC, VUT 250 V EC** units are available only with the A14 automation system.





■ **Freeze protection**

Freeze protection is provided by the shutdown of the supply fan. In the **VUT/VUE VB EC A21** units it is possible to connect a preheater to protect the unit from freezing.

Designation key

Series	Rated air flow [m ³ /h]	Installation features	Casing design	Bypass	Motor type	Control
VUT: ventilation with heat recovery VUE: ventilation with energy recovery	160, 200, 250, 300, 350, 550	V: vertical	- by default 1: casing modification	- : without bypass B: with bypass	EC: synchronous electronically commutated motor	A14 A21

Control and automation

Functions	A21	A14
Wired remote control panel	Option (A22) 	A14 
Wired remote LCD control panel	Option (A25) 	-
Wireless remote control panel	Option (A22 Wi-Fi) 	-
BMS	RS-485 Wi-Fi Ethernet MODBUS (RTU, TCP)	-
Service Vents Cloud Server	+	-
Control by a mobile application via Wi-Fi	+	-
Freeze protection	+	+
Bypass	Auto + manual	Manual
Week-scheduled operation	+	-
Filter replacement indication	According to filter timer	According to filter timer
	According to pressure switch of filter clogging (only for VUT/VUE 550 VB EC A21)	
Alarm indication	+	+
Speed selection	+	+
Timers	+	-
RH% sensor	Option	Option
CO ₂ sensor	Option	Option
VOC sensor	Option	Option
PM2.5 sensor	Option	Option
Boost mode	+	-
Fireplace mode	+	-
Preheater connection	Option	-
Reheater connection	Option	-
Cooler connection	Option	-
Fire alarm sensor	Option	Option
Minimum supply air temperature control	+	-

Installation

The units are designed for wall or floor mounting. Access for maintenance of units and filters is possible from the right and left side.

Unit design

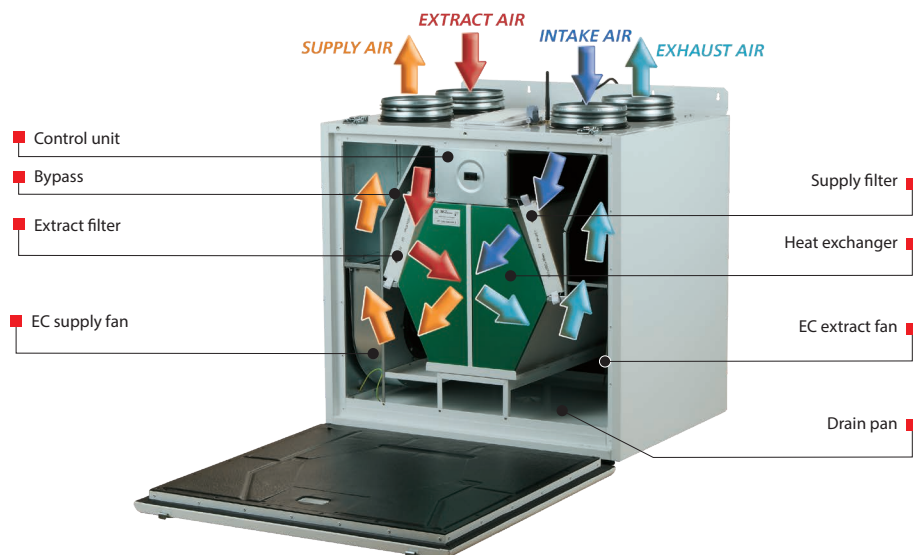

VENTS
 VUT/VUE
 VB EC
 AIR HANDLING UNITS WITH
 HEAT RECOVERY

AIR HANDLING UNITS WITH HEAT RECOVERY

Technical data

	VUT 160 V EC	VUE 160 V EC	VUT 160 VB EC	VUE 160 VB EC	VUT 160 V1 EC	VUE 160 V1 EC	VUT 160 V1B EC	VUE 160 V1B EC
Unit voltage [V/50 (60) Hz]					1~230			
Maximum power [W]					57			
Maximum current [A]					0.5			
Maximum air flow [m ³ /h]					200			
RPM [min ⁻¹]					3770			
Sound pressure level at 3 m distance [dBA]	24				22			
Transported air temperature [°C]					from -25 up to +40			
Casing material	painted steel							
Insulation	20 mineral wool				40 mineral wool			
Extract filter					G4			
Supply filter	F7 (optionally G4)							
Connected air duct diameter [mm]	Ø125							
Weight [kg]	34		36		42		44	
Heat recovery efficiency [%]	from 85 up to 93	from 76 up to 92	from 85 up to 93	from 76 up to 92	from 85 up to 93	from 76 up to 92	from 85 up to 93	from 76 up to 92
Heat exchanger type	counter-flow							
Heat exchanger material	polystyrene	enthalpy	polystyrene	enthalpy	polystyrene	enthalpy	polystyrene	enthalpy
Energy efficiency class for A14, A21	A+	A	A+	A	A+	A	A+	A

VENTS VUT/VUE V(B) EC

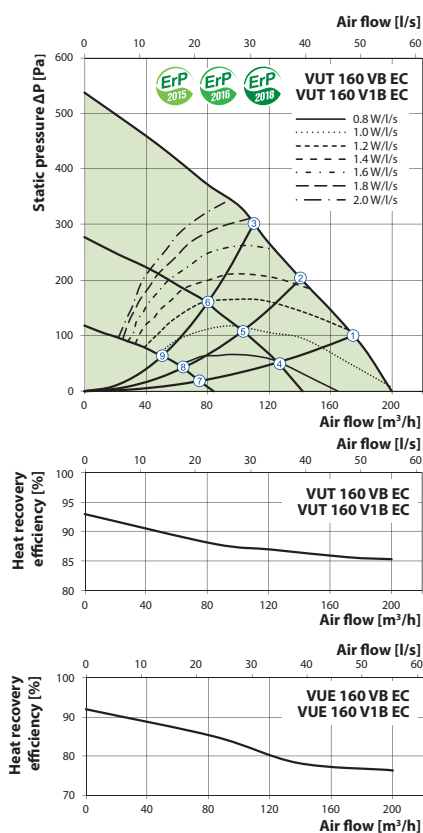

VUT 160 V EC, VUE 160 V EC, VUT 160 VB EC, VUE 160 VB EC

A-weighted sound power level	Gen. dBA	Octave frequency band [Hz]							LpA, 3 m dBA	LpA, 1 m dBA		
		63	125	250	500	1000	2000	4000			8000	
L _{WA} to supply air inlet	dBA	52	28	46	49	41	35	33	36	29		
L _{WA} to supply air outlet	dBA	60	32	52	58	47	37	36	41	35		
L _{WA} to exhaust air inlet	dBA	51	27	45	49	41	36	32	35	29		
L _{WA} to exhaust air outlet	dBA	60	31	50	59	48	36	36	41	32		
L _{WA} to environment	dBA	45	25	41	42	34	31	28	27	22	24	34

VUT 160 V1 EC, VUE 160 V1 EC, VUT 160 V1B EC, VUE 160 V1B EC

A-weighted sound power level	Gen. dBA	Octave frequency band [Hz]							LpA, 3 m dBA	LpA, 1 m dBA		
		63	125	250	500	1000	2000	4000			8000	
L _{WA} to supply air inlet	dBA	52	28	46	49	41	35	33	36	29		
L _{WA} to supply air outlet	dBA	60	32	52	58	47	37	36	41	35		
L _{WA} to exhaust air inlet	dBA	51	27	45	49	41	36	32	35	29		
L _{WA} to exhaust air outlet	dBA	60	31	50	59	48	36	36	41	32		
L _{WA} to environment	dBA	43	23	39	39	33	29	25	25	20	22	32

	VUT 200 V EC	VUE 200 V EC	VUT 200 VB EC	VUE 200 VB EC	VUT 250 VB EC	VUE 250 VB EC	VUT 250 VB EC	VUE 250 VB EC
Unit voltage [V/50 (60) Hz]	1~230				1~230			
Maximum power [W]	112				115			
Maximum current [A]	0.9				0.9			
Maximum air flow [m³/h]	250				290			
RPM [min ⁻¹]	2050				2050			
Sound pressure level at 3 m distance [dBA]	24				25			
Transported air temperature [°C]	from -25 up to +40				from -25 up to +40			
Casing material	painted steel				painted steel			
Insulation	25 mineral wool				30 mineral wool			
Extract filter	G3				G4			
Supply filter	G3				G4, F7			
Connected air duct diameter [mm]	Ø125				Ø160			
Weight [kg]	45				51			
Heat recovery efficiency [%]	from 83 up to 98	from 74 up to 94	from 83 up to 98	from 74 up to 94	from 85 up to 94	from 78 up to 90	from 85 up to 94	from 78 up to 90
Heat exchanger type	counter-flow				counter-flow			
Heat exchanger material	polystyrene	enthalpy	polystyrene	enthalpy	polystyrene	enthalpy	polystyrene	enthalpy
Energy efficiency class for A14, A21	A+	A	A+	A	A+	A+	A+	A+

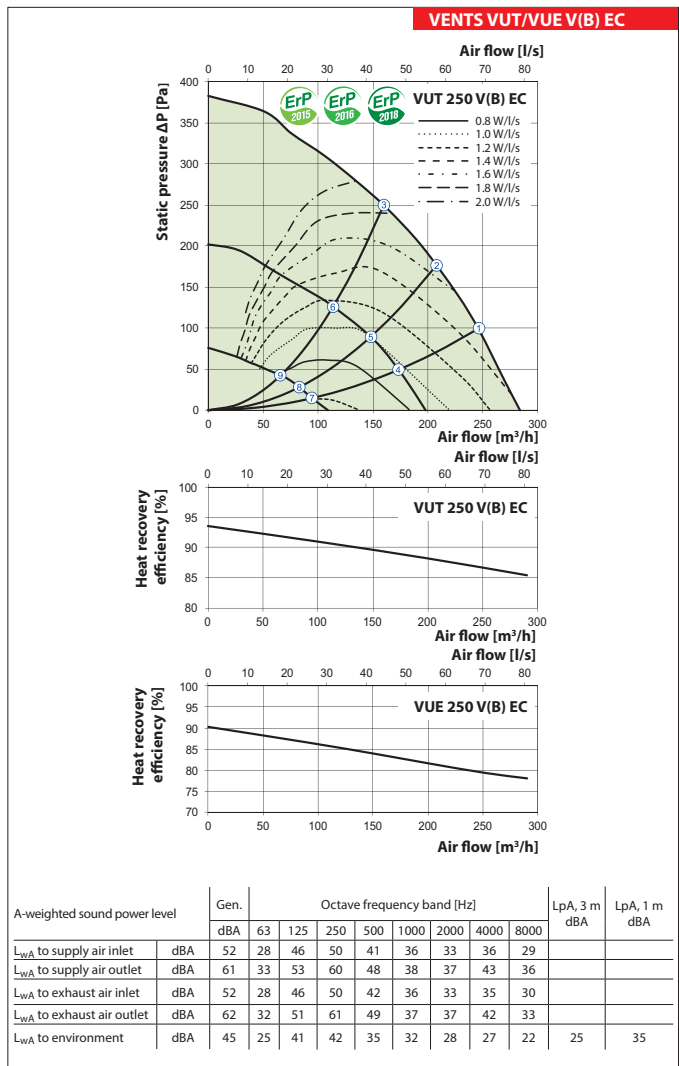
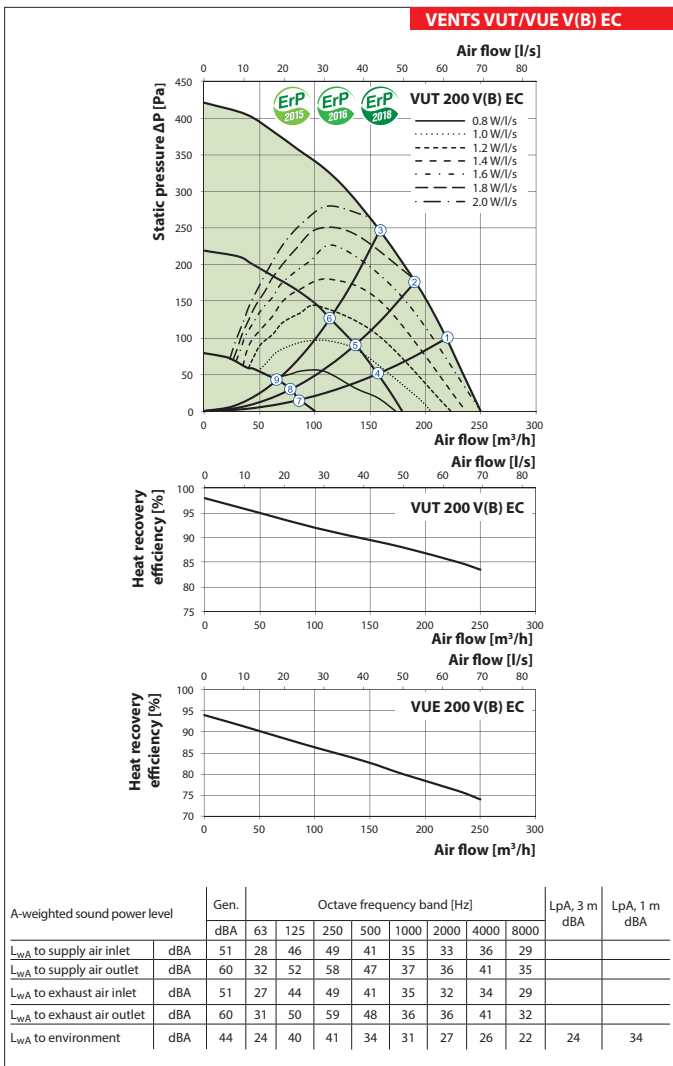

AIR HANDLING UNITS WITH HEAT RECOVERY
 VENTs VUT/VUE V(B) EC

AIR HANDLING UNITS WITH HEAT RECOVERY

Technical data

	VUT 350 V1B EC	VUE 350 V1B EC	VUT 350 VB EC	VUE 350 VB EC
Unit voltage [V/50 (60) Hz]	1~230		1~230	
Maximum power [W]	169		178	
Maximum current [A]	1.3		1.4	
Maximum air flow [m³/h]	420		450	
RPM [min⁻¹]	3200		3200	
Sound pressure level at 3 m distance [dBA]	28		28	
Transported air temperature [°C]	from -25 up to +40		from -25 up to +40	
Casing material	painted steel		painted steel	
Insulation	40 mineral wool		40 mineral wool	
Extract filter	G4		G4	
Supply filter	F7 (optionally G4)		F7 (optionally G4)	
Connected air duct diameter [mm]	Ø160		Ø160	
Weight [kg]	57		64	
Heat recovery efficiency [%]	from 85 up to 92	from 74 up to 91	from 85 up to 92	from 73 up to 91
Heat exchanger type	counter-flow		counter-flow	
Heat exchanger material	polystyrene	enthalpy	polystyrene	enthalpy
Energy efficiency class for A14, A21	A+	A	A+	A

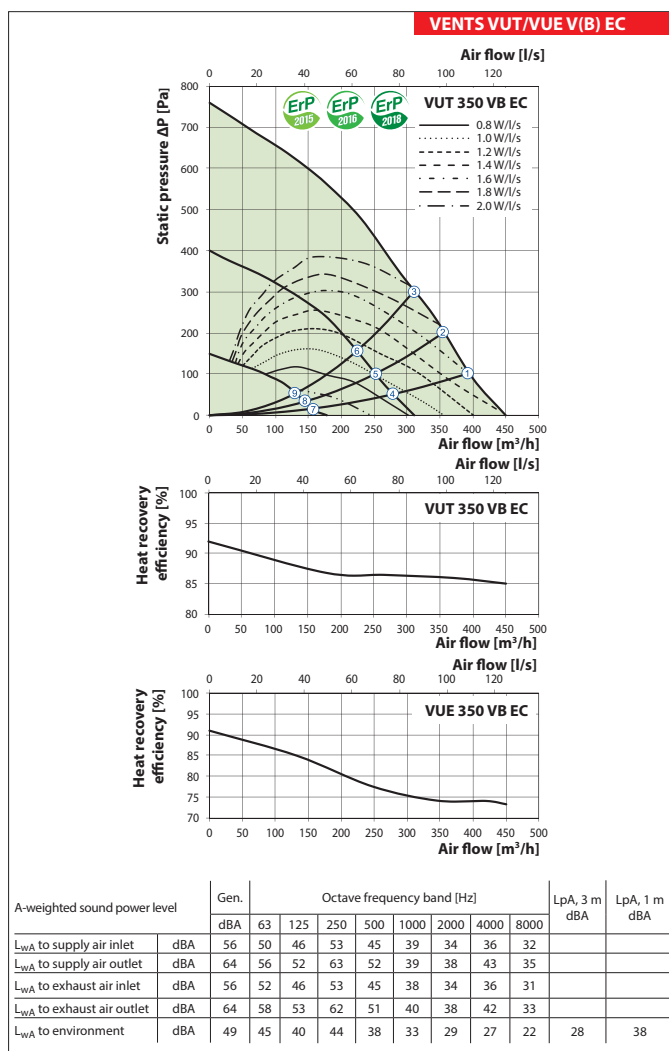
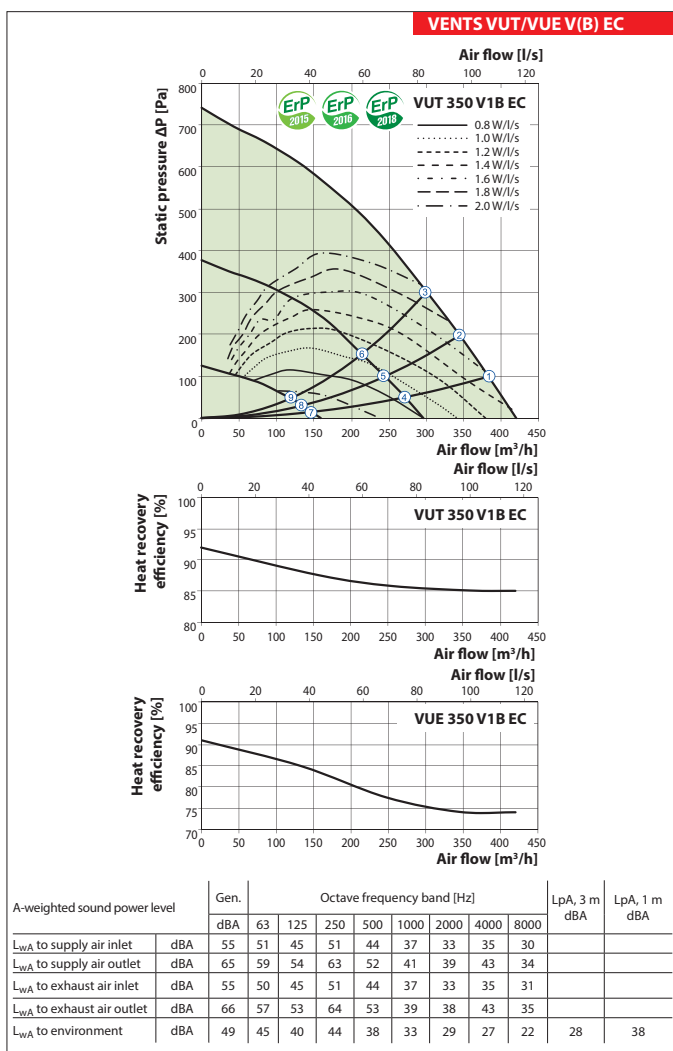

Technical data

	VUT 550 VB EC	VUE 550 VB EC
Unit voltage [V/50 (60) Hz]	1~230	
Maximum power [W]	337	
Maximum current [A]	2.4	
Maximum air flow [m ³ /h]	690	
RPM [min ⁻¹]	2860	
Sound pressure level at 3 m distance [dBA]	26	
Transported air temperature [°C]	from -25 up to +40	
Casing material	painted steel	
Insulation	40 mineral wool	
Extract filter	G4	
Supply filter	F7 (optionally G4)	
Connected air duct diameter [mm]	Ø200	
Weight [kg]	82	
Heat recovery efficiency [%]	from 84 up to 92	from 73 up to 91
Heat exchanger type	counter-flow	
Heat exchanger material	polystyrene	enthalpy
Energy efficiency class for A14, A21	A+	A

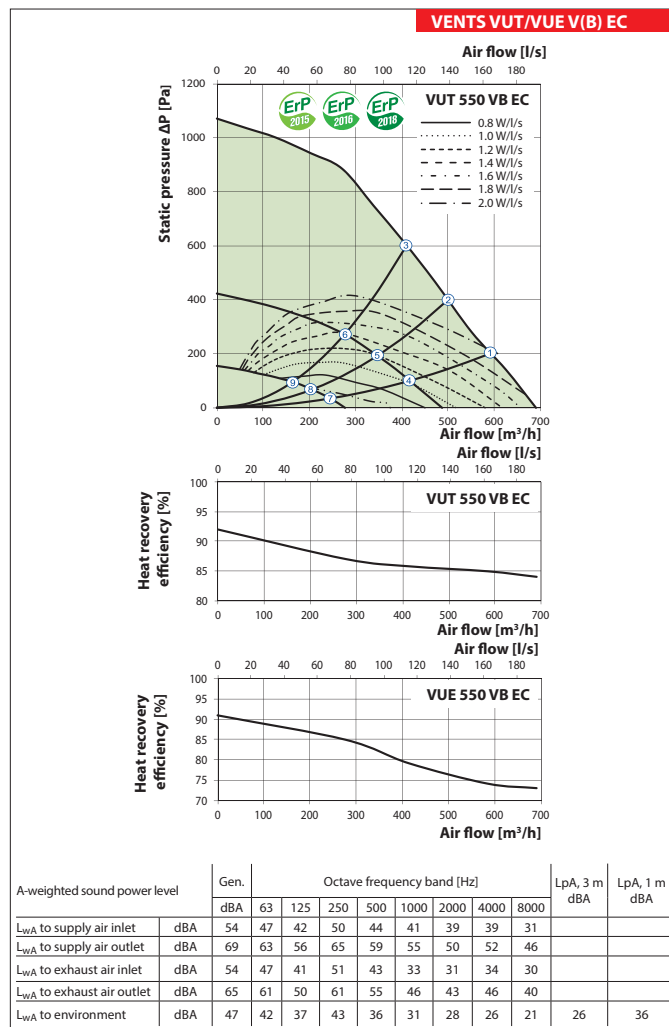

VENTS VUT/VUE VB EC
 AIR HANDLING UNITS WITH HEAT RECOVERY

Technical data

VUT 200 V(B) EC			
Outlet spigot configuration	Air flow [l/s]	Specific power input [W/l/s]	Heat exchange efficiency [%]
Kitchen + 1 additional room with high level of humidity	21	0.67	87
Kitchen + 2 additional rooms with high levels of humidity	29	0.69	85
Kitchen + 3 additional rooms with high levels of humidity	37	0.88	84
Kitchen + 4 additional rooms with high levels of humidity	45	1.13	83
Kitchen + 5 additional rooms with high levels of humidity	53	1.37	83

VUT 250 V(VB) EC			
Outlet spigot configuration	Air flow [l/s]	Specific power input [W/l/s]	Heat exchange efficiency [%]
Kitchen + 1 additional room with high level of humidity	21	0.65	92
Kitchen + 2 additional rooms with high levels of humidity	29	0.68	91
Kitchen + 3 additional rooms with high levels of humidity	37	0.77	90
Kitchen + 4 additional rooms with high levels of humidity	45	0.94	89
Kitchen + 5 additional rooms with high levels of humidity	53	1.12	88
Kitchen + 6 additional rooms with high levels of humidity	61	1.35	87
Kitchen + 7 additional rooms with high levels of humidity	69	1.70	86

VUT 350 VB EC			
Outlet spigot configuration	Air flow [l/s]	Specific power input [W/l/s]	Heat exchange efficiency [%]
Kitchen + 1 additional room with high level of humidity	21	0.71	88
Kitchen + 2 additional rooms with high levels of humidity	29	0.64	88
Kitchen + 3 additional rooms with high levels of humidity	37	0.68	87
Kitchen + 4 additional rooms with high levels of humidity	45	0.76	86
Kitchen + 5 additional rooms with high levels of humidity	53	0.86	86
Kitchen + 6 additional rooms with high levels of humidity	61	1.07	85
Kitchen + 7 additional rooms with high levels of humidity	69	1.26	85

VUT 550 VB EC			
Outlet spigot configuration	Air flow [l/s]	Specific power input [W/l/s]	Heat exchange efficiency [%]
Kitchen + 1 additional room with high level of humidity	21	0.71	87
Kitchen + 2 additional rooms with high levels of humidity	29	0.63	88
Kitchen + 3 additional rooms with high levels of humidity	37	0.63	88
Kitchen + 4 additional rooms with high levels of humidity	45	0.72	88
Kitchen + 5 additional rooms with high levels of humidity	53	0.84	88
Kitchen + 6 additional rooms with high levels of humidity	61	0.98	87
Kitchen + 7 additional rooms with high levels of humidity	69	1.16	87

Calculation of air temperature downstream of the heat exchanger:

$$t = t_{\text{outd}} + k_{\text{hr}} * (t_{\text{extr}} - t_{\text{outd}}) / 100,$$

where

t_{outd} – outdoor air temperature [°C]

t_{extr} – extract air temperature [°C]

k_{hr} – heat exchanger efficiency (according to the diagram) [%]

Point	Power [W]					
	VUT 160 V EC VUT 160 VB EC VUT 160 V1 EC VUT 160 V1B EC VUE 160 V EC VUE 160 VB EC VUE 160 V1 EC VUE 160 V1B EC	VUT 200 V EC VUE 200 V EC VUT 200 VB EC VUE 200 VB EC	VUT 250 V EC VUE 250 V EC VUT 250 VB EC VUE 250 VB EC	VUT 350 V1B EC VUE 350 V1B EC	VUT 350 VB EC VUE 350 VB EC	VUT 550 VB EC VUE 550 VB EC
1	57	103	106	168	177	337
2	56	95	95	166	175	337
3	54	88	82	162	170	337
4	28	42	44	65	71	118
5	27	38	40	64	71	113
6	26	36	36	62	69	107
7	14	16	16	18	21	34
8	13	15	15	17	21	66
9	13	15	15	17	21	32

Point	Sound pressure level at 3 m distance [dBA]					
	VUT 160 V EC VUT 160 VB EC VUT 160 V1 EC VUT 160 V1B EC VUE 160 V EC VUE 160 VB EC VUE 160 V1 EC VUE 160 V1B EC	VUT 200 V EC VUE 200 V EC VUT 200 VB EC VUE 200 VB EC	VUT 250 V EC VUE 250 V EC VUT 250 VB EC VUE 250 VB EC	VUT 350 V1B EC VUE 350 V1B EC	VUT 350 VB EC VUE 350 VB EC	VUT 550 VB EC VUE 550 VB EC
1	24 (34)	24 (34)	25 (35)	28 (38)	28 (38)	26 (36)
2	23 (33)	23 (33)	24 (34)	27 (37)	27 (37)	26 (36)
3	23 (33)	23 (33)	24 (34)	27 (37)	27 (37)	25 (35)
4	20 (30)	19 (29)	20 (30)	23 (33)	23 (33)	24 (34)
5	20 (30)	18 (28)	19 (29)	22 (32)	22 (32)	24 (34)
6	20 (30)	18 (28)	19 (29)	22 (32)	22 (32)	22 (32)
7	13 (23)	12 (22)	13 (23)	15 (25)	15 (25)	15 (25)
8	13 (23)	12 (22)	12 (22)	14 (24)	14 (24)	14 (24)
9	13 (23)	11 (21)	12 (22)	14 (24)	14 (24)	13 (23)





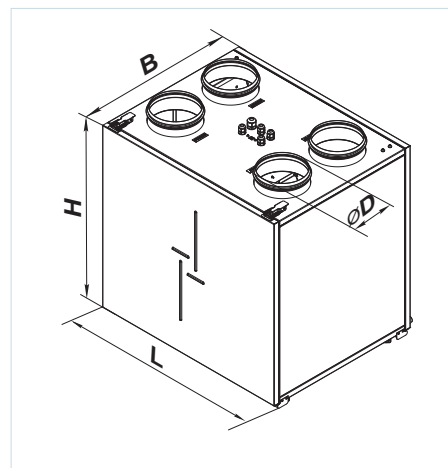

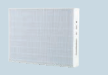

Overall dimensions

Model	Dimensions [mm]			
	Ø D	B	H	L
VUT/VUE 160 V EC	125	330	550	600
VUT/VUE 160 V1 EC	125	370	590	640
VUT/VUE 160 VB EC	125	330	580	600
VUT/VUE 160 V1B EC	125	370	620	640
VUT/VUE 200 V EC	125	290	771	564
VUT/VUE 200 VB EC	125	290	771	564
VUT/VUE 250 V EC	160	450	788	565
VUT/VUE 250 VB EC	160	450	788	565
VUT/VUE 350 VB EC	160	583	675	730
VUT/VUE 350 V1B EC	160	470	675	730
VUT/VUE 550 VB EC	200	720	675	823



AIR HANDLING UNITS WITH
 VUT/VUE
 HEAT RECOVERY
 VB EC

Accessories for air handling units

Model	Panel filter G3	Panel filter G4	Panel filter F7	LCD control panel	Control panel	Control panel with Wi-Fi	Indoor humidity sensor	CO ₂ sensor with indication	CO ₂ sensor	Humidity sensor
										
VUT 160 V EC A21				A25	A22	A22 Wi-Fi				
VUT 160 V EC A14				-	-	-				
VUE 160 V EC A21				A25	A22	A22 Wi-Fi				
VUE 160 V EC A14				-	-	-				
VUT 160 VB EC A21				A25	A22	A22 Wi-Fi				
VUT 160 VB EC A14				-	-	-				
VUE 160 VB EC A21				A25	A22	A22 Wi-Fi				
VUE 160 VB EC A14		SF	SF	-	-	-				
VUT 160 V1 EC A21	-	285x195x10 G4	285x195x10 F7	A25	A22	A22 Wi-Fi				
VUT 160 V1 EC A14				-	-	-				
VUE 160 V1 EC A21				A25	A22	A22 Wi-Fi				
VUE 160 V1 EC A14				-	-	-				
VUT 160 V1B EC A21				A25	A22	A22 Wi-Fi				
VUT 160 V1B EC A14				-	-	-				
VUE 160 V1B EC A21				A25	A22	A22 Wi-Fi				
VUE 160 V1B EC A14				-	-	-				
VUT 200 V EC A14										
VUT 200 VB EC A14	SF									
VUE 200 V EC A14	264x195x18 G3	-	-	-	-	-	HV2	CO2-1	CO2-2	HR-S
VUE 200 VB EC A14										
VUT 250 V EC A14				-	-	-				
VUT 250 VB EC A21				A25	A22	A22 Wi-Fi				
VUT 250 VB EC A14	-	SF	SF	-	-	-				
VUE 250 V EC A14		417x200x18 G4	417x184x18 F7	-	-	-				
VUE 250 VB EC A21				A25	A22	A22 Wi-Fi				
VUT 350 V1B EC A21				A25	A22	A22 Wi-Fi				
VUT 350 V1B EC A14				-	-	-				
VUE 350 V1B EC A21	-	SF	SF	A25	A22	A22 Wi-Fi				
VUE 350 V1B EC A14		384x196x40 G4	384x196x40 F7	-	-	-				
VUT 350 VB EC A21				A25	A22	A22 Wi-Fi				
VUT 350 VB EC A14				-	-	-				
VUE 350 VB EC A21		SF	SF	A25	A22	A22 Wi-Fi				
VUE 350 VB EC A14		500x196x40 G4	500x196x40 F7	-	-	-				
VUT 550 VB EC A21				A25	A22	A22 Wi-Fi				
VUT 550 VB EC A14				-	-	-				
VUE 550 VB EC A21	-	SF	SF	A25	A22	A22 Wi-Fi				
VUE 550 VB EC A14		630x198x40 G4	630x198x40 F7	-	-	-				

Model	VOC sensor (0-10 V)	CO ₂ sensor (0-10 V)	Humidity sensor (0-10 V)	Kitchen hood	Electric heater for preheating	Electric reheater	Hydraulic U-trap	Air damper	Electric actuator	Summer block					
VUT 160 V EC A21	DPWQ30600	DPWQ40200	DPWC11200	KH-1	NKP-125	NKD-125	SH-32	KRV 125	LF230	VL C6 366/285					
VUT 160 V EC A14	-	-	-		-	-					-				
VUE 160 V EC A21	DPWQ30600	DPWQ40200	DPWC11200		NKP-125	NKD-125	-								
VUE 160 V EC A14	-	-	-		-	-	-								
VUT 160 VB EC A21	DPWQ30600	DPWQ40200	DPWC11200		NKP-125	NKD-125	SH-32								
VUT 160 VB EC A14	-	-	-		-	-	-								
VUE 160 VB EC A21	DPWQ30600	DPWQ40200	DPWC11200		NKP-125	NKD-125	-								
VUE 160 VB EC A14	-	-	-		-	-	-								
VUT 160 V1 EC A21	DPWQ30600	DPWQ40200	DPWC11200		NKP-125	NKD-125	SH-32								
VUT 160 V1 EC A14	-	-	-		-	-	-								
VUE 160 V1 EC A21	DPWQ30600	DPWQ40200	DPWC11200		NKP-125	NKD-125	-								
VUE 160 V1 EC A14	-	-	-		-	-	-								
VUT 160 V1B EC A21	DPWQ30600	DPWQ40200	DPWC11200		NKP-125	NKD-125	SH-32								
VUT 160 V1B EC A14	-	-	-		-	-	-								
VUE 160 V1B EC A21	DPWQ30600	DPWQ40200	DPWC11200		NKP-125	NKD-125	-								
VUE 160 V1B EC A14	-	-	-		-	-	-								
VUT 200 V EC A14	-	-	-		KH-1	-	-				SH-32	KRV 125	LF230	VL C6 366/240	
VUT 200 VB EC A14	-	-	-			-	-				-			-	-
VUE 200 V EC A14	-	-	-			-	-				-			-	VL C6 366/240
VUE 200 VB EC A14	-	-	-			-	-				-			-	-
VUT 250 V EC A14	-	-	-		KH-1	-	-				SH-32	KRV 160	LF230	VL C6 366/384	
VUT 250 VB EC A21	DPWQ30600	DPWQ40200	DPWC11200			NKP-160	NKP-160							-	
VUT 250 VB EC A14	-	-	-			-	-							-	
VUE 250 V EC A14	-	-	-			-	-							-	
VUE 250 VB EC A21	DPWQ30600	DPWQ40200	DPWC11200	NKP-160		NKP-160	-								
VUT 350 V1B EC A21	DPWQ30600	DPWQ40200	DPWC11200	NKP-160		NKD-160	SH-32								
VUT 350 V1B EC A14	-	-	-	-		-	-								
VUE 350 V1B EC A21	DPWQ30600	DPWQ40200	DPWC11200	NKP-160		NKD-160	-								
VUE 350 V1B EC A14	-	-	-	-		-	-								
VUT 350 VB EC A21	DPWQ30600	DPWQ40200	DPWC11200	NKP-160		NKD-160	SH-32								
VUT 350 VB EC A14	-	-	-	-		-	-								
VUE 350 VB EC A21	DPWQ30600	DPWQ40200	DPWC11200	NKP-160		NKD-160	-								
VUE 350 VB EC A14	-	-	-	-		-	-								
VUT 550 VB EC A21	DPWQ30600	DPWQ40200	DPWC11200	NKP-200		NKD-200	SH-32								
VUT 550 VB EC A14	-	-	-	-		-	-								
VUE 550 VB EC A21	DPWQ30600	DPWQ40200	DPWC11200	NKP-200		NKD-200	-								
VUE 550 VB EC A14	-	-	-	-		-	-								

VENTS
VUT/VUE
VB EC
AIR HANDLING UNITS WITH
HEAT RECOVERY

Application options

Ventilation hood



Ceiling connector with a disk valve

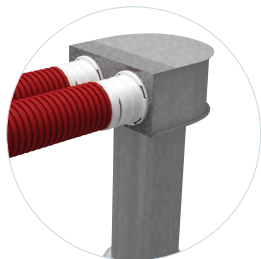

Isovent 150 insulated air duct

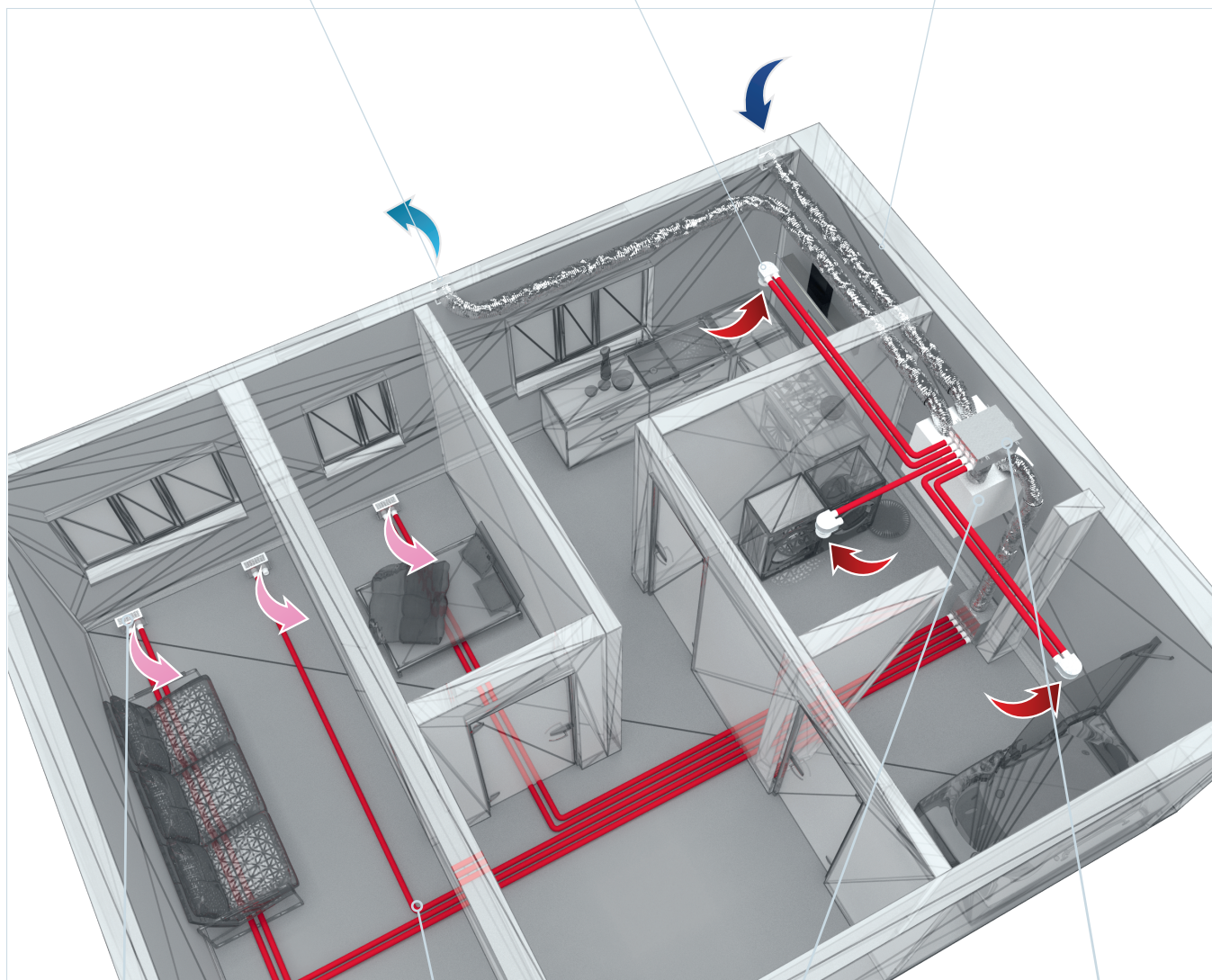

Floor connector with a grille

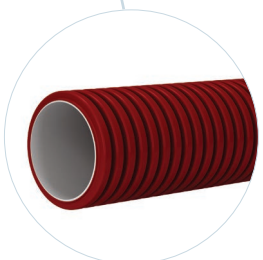

FlexiVent air duct



Air handling unit

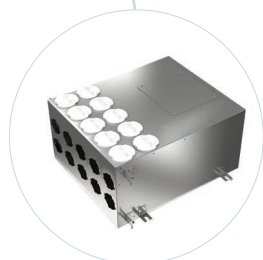

Collector