

User's Manual

CONTENT

1. Purpose	p. 3
2. Delivery set	p. 3
3. Basic technical characteristics	p. 3
4. Safety requirements	p. 8
5. Fan structure	p. 8
6. TSC unit description and operating principle	p. 9
7. Installation and preparation for operation	p. 12
8. Fan connection to the power network	p. 13
9. Mounting options	p. 14
10. Fan wiring diagram to the power network	p. 18
11. Maintenance	p. 21
12. Storage regulations	p. 21
13. Manufacturer's warranty	p. 21
14. Failures and troubleshooting methods	p. 22
15. Acceptance certificate	p. 23
16. Warranty certificate	p. 24

Centrifugal electrical-driven fan VENTS KSD in metal sound-insulated casing with double-inlet impeller, \varnothing 180 to 320 mm and forward curved blades, hereinafter referred as the fan, is designed for supply and exhaust ventilation of residential, public and industrial premises with high noise level requirements.

The fan shall be installed horizontally on the level surface or suspended. It is designed for connection to \varnothing 250, 315 mm round ducts.

The transferred air shall not contain any dust or other solid particles, sticky substances and fibrous materials.

The fans are designed for continuous operation with permanent power supply.

The fan is easy to use and designed for continuous operation at the temperature ranging from -25°C to $+55^{\circ}\text{C}$.

Protection rating from access to dangerous parts and water penetration is IPX4

Delivery set includes:

- Fan - 1 pce;
- Operating manual - 1 pce;
- Packing box - 1 pce.

The fan designation, fan options, operating principle and connecting dimensions are shown in tables 1, 2 and fig. 1-6

The fan design is regularly being improved, that is why some models can slightly differ from those ones described in this manual.

If the air capacity and current consumption values exceed the permissible values for the given standard size and no motor overload protection is provided the fan operation and trial run are expressly prohibited.

Purpose

Delivery set

Basic technical characteristics

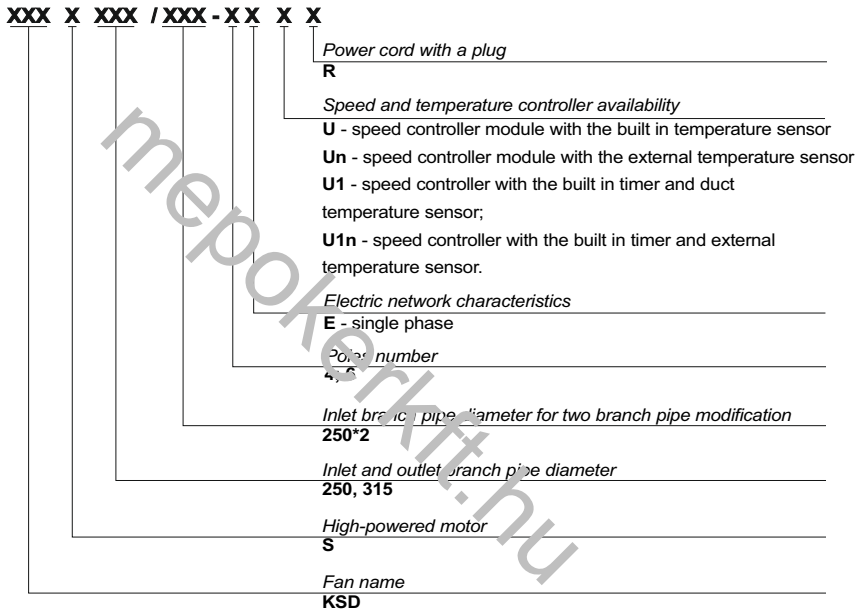

PROHIBITED:

**FAN
DESIGNATION
KEY**

Designation key example:

VENTS KSD 250-4E - centrifugal fan powered by four-pole motor in meal sound-insulated casing designed for connection with \varnothing 250 mm round air ducts at the fan inlet and outlet.

VENTS KSD 315 / 250*2-6E - centrifugal fan powered by 6-pole motor in metal sound-insulated casing designed for connection with two \varnothing 250 mm inlet air ducts and one \varnothing 315 mm outlet air duct.

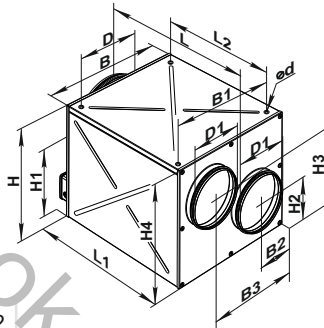
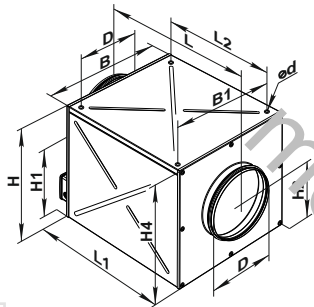
VENTS KSD S 315-4E Un R - centrifugal fan powered by four-pole high-powered motor in metal sound-insulated casing designed for connection with \varnothing 315 mm inlet and outlet air ducts, electronic speed control module with temperature sensor operating in temperature sensor delay mode, external temperature sensor and built-in power cord with plug.



1 Overall and connection dimensions of KSD fan with one inlet and one outlet flange.

2 Overall and connection dimensions of KSD fan with two inlet flanges and one outlet flange.

Fan model	Dimensions [mm]											Weight [kg]
	ØD	ød	B	B1	H	H1	H2	H4	L	L1	L2	
KSD 315-6E	313	M8	600	550	500	340	251	537	680	580	510	31
KSD 315-4E	313	M8	600	550	500	340	251	537	680	580	510	33
KSD S 315-4E	313	M8	650	610	530	367	266	567	735	635	570	38
KSD S 315-6E	313	M10	670	620	610	450	306	658	825	725	660	45

table 1

Fan model	Dimensions [mm]														Weight [kg]	
	ØD	ØD1	ød	B	B1	B2	B3	H	H1	H2	H3	H4	L	L1		L2
KSD 315/250*2-6E	313	248	M8	600	550	171	431	500	340	176	326	537	680	580	510	31
KSD 315/250*2-4E	313	248	M8	600	550	171	431	500	340	176	326	537	680	580	510	33
KSD S 315/250*2-4E	313	248	M8	650	610	188	465	530	367	186	346	567	735	635	570	38
KSD S 315/250*2-6E	313	248	M10	670	620	216	457	610	450	186	427	658	825	725	660	45

table 2

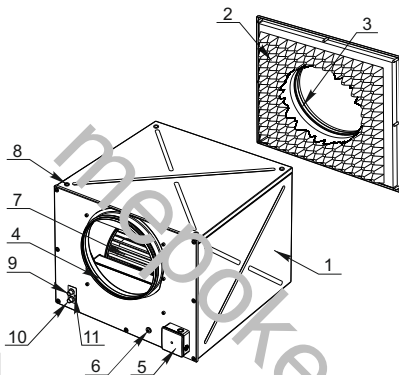

3

- 1-fan casing
- 2-sound-insulating layer
- 3-inlet flange
- 4-outlet flange
- 5-terminal box
- 6-ground connection
- 7-impeller
- 8-mounting nut
- 9-speed controller
- 10-control knob for the temperature threshold setting
- 11-TSC module LED light indicator

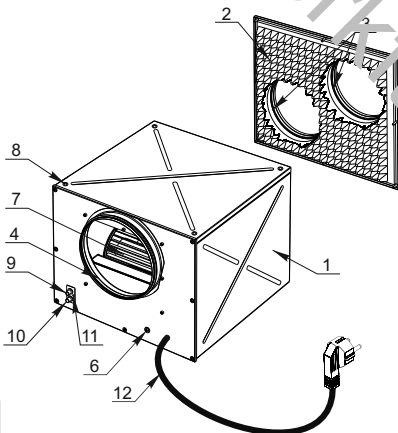

4

- 1-Fan casing
- 2-sound-insulating layer
- 3-inlet flange
- 4-outlet flange
- 5-fan ground connection
- 6-impeller
- 7-mounting nut
- 8-control knob for speed control setting
- 9-control knob for setting of the temperature threshold
- 10-TSC module LED light indicator
- 11-Power cord with a plug

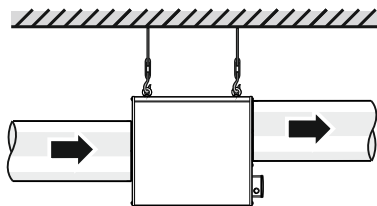

5

KSD fan installation and operation example

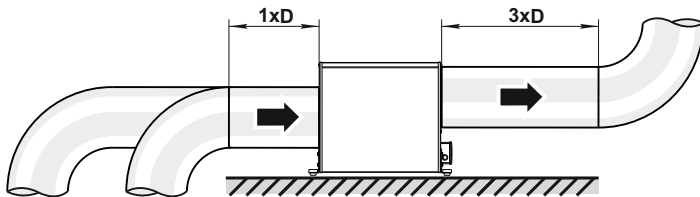

6

General installation advices for KSD fans

**PROHIBITED:**

Fan operation beyond the specified temperature conditions ranging from -25°C to +55°C or in premises with aggressive impurities in the air and in explosive environment is prohibited.

Safety requirements

Fan mounting and connection shall be performed by an authorized electrical technician in compliance with the acting norms and standards.

Fan maintenance and repair works shall be performed only after its disconnecting from power supply network. Before connecting the fan to the power supply network, please make sure that the fan is free of any visible damages or any foreign objects inside the casing that may damage the impeller. Power supply cable must not be in contact with any hot fan and air duct surfaces.

**WARNING**

Do not use the fan in the explosive or fire hazardous environment. The transferred air shall not contain any dust or other solid particles, sticky substances and fibrous materials.

FAN STRUCTURE

The fan (fig. 3,4) consists of metal casing 1 internally insulated with sound-insulating layer 2, inlet flange 3 and outlet flange 4 for one flange modification (fig. 3) or two inlet flanges 3 and inlet outlet flange 4 for two inlet flanges modification (fig. 4). The flange diameters are compatible with the connected air duct diameter.

Fan connection to the single-phase power network is performed with a terminal box 5 or a power cord with a plug 12 for R fan modification depending on the model.

The fan casing is equipped with the ground connection 6. The impeller 7 is mounted in the motor shaft. The mounting nuts 8 are inserted on the top of the casing to facilitate the fan suspension to a horizontal surface by means of mounting eye bolts which are not included in the delivery set. The fan modifications with TSC electronic speed module with the temperature sensor on the casing front panel have the control knob for speed setting 9, control knob for temperature threshold setting 10 and electronic LED light indicator 11.

The fan design provides two options for the fan connection to the network:

- through the fan terminal box (fig. 3);
- through the power cord with the plug for R modification (fig. 4).

**TSC module
description
and operating
principle**

TSC electronic module is designed for the fan speed control and temperature regulation. KSD U, KSD Un fan modifications provide automatic speed control and air capacity regulation as a function of the air temperature in the duct.

KSD U fan modification includes built-in temperature sensor, KSD Un fan modification includes external 4 m temperature sensor.

The following control knobs are located at TSC module front panels:

- * control knob for motor speed setting;
- * control knob for temperature threshold setting

The LED light indicator is located at the front panel to indicate the fan mode operation.

TSC module operating pattern.

set the desirable air temperature in the duct by means of rotating the temperature control knob (setting the temperature threshold).

set the required control speed by means of rotating the speed control knob (setting the air capacity).

As the air temperature in the duct rises and the set temperature threshold is exceeded the controller sets the fan motor for the maximum rotation speed (maximum air capacity).

As the air in the duct goes down below the set temperature threshold the controller switches the fan motor to the preset speed.

The following switch delay modes are available to disable frequent motor switching:

- temperature sensor delay;
- timer delay.

Operating pattern of TSC electronic speed control module with temperature delay mode (KSD, KSD Un modifications): as the air temperature rises by more than 2°C above the set temperature threshold the motor is switched for the maximum speed.

The reset to the preset low speed is effected as the temperature drops below the set temperature threshold. The pattern is applied to keep the air temperature at a precise level up to 2°C. In this case the fan switching is rare.

Operating pattern of TSC electronic speed control module with timer delay mode (KSD U1, KSD U1n modifications): as the temperature exceeds the set temperature threshold the motor is switched for the maximum speed and simultaneously the delay timer switches on. The motor switches to the preset low speed after the temperature drops below the set threshold after the delay timer countdown. The pattern is applied to keep the air temperature at a precise level up to 2°. In this case the fan switchings are more frequent as compared to the temperature sensor delay pattern of, however the intervals do not exceed 5 minutes.

Operating pattern example of TSC electronic speed control module with temperature delay mode (KSD, KSD Un modifications)

Initial conditions

- set rotation speed = 60% of maximum speed
- set operating threshold = 25°C
- air temperature in the duct =20°C

1. Motor operates with the motor speed =60%
2. The temperature in the duct rises
the motor operates with the set rotation speed =60%
3. The temperature in the duct reaches 27°C
the motor switches to the rotation speed =100%

temperature in the duct goes down motor operates with the rotation speed =100%
temperature in the duct reaches 25°C
motor switches to the preset rotation speed =60%

Operating pattern example of TSC electronic speed control module with timer delay mode (KSD U1, KSD U1n modifications)

Initial conditions

- set rotation speed = 60% of maximum speed
- set operating threshold = 25°C
- air temperature in the duct =20°C

1. Motor operates with the motor speed =60%
2. The temperature in the duct rises, reaches 25°C and keeps rising
3. The motor switches to the rotation speed =100%, at the same moment the 5 minutes timer activates
4. The temperature in the duct goes down, motor operates with the rotation speed =100%
5. The temperature in the duct reaches 25°C and keeps going down
6. After the timer stops, the motor switches to the preset rated speed (=60%). After the speed switch the timer switches again for 5 minutes on.
7. The temperature in the duct rises, reaches 25°C and keeps rising
8. after the timer stops, the motor switches to the maximum speed (=100%). After the speed switch the timer switches again for 5 minutes on.

Thus, in timer delay pattern the delay timer activates every time the fan speed changes.

**WARNING**

Installation and connection of the fan should be performed with disconnected power network only.

Installation and preparation for operation

After the fan unpacking make sure of no damages in the power supply line, check the fan casing for no hollows and other distortions. The impeller is to rotate smoothly and be not in contact with the flange and/or the casing.

Observe general and special precaution safety precautions during the fan preparation for operation.

The fan shall be provided with the ground connection. The circuit breaker shall be installed in such a way as to enable observing the fan start-up. The fan is mounted by means of the seat angles to the floor or suspended by means of the eye bolts to a horizontal flat surface.

The fan mounting options are shown at fig. 7-18. Access shall be provided for the fan maintenance. To reduce the losses due to the air flow turbulence a straight air duct section shall be installed at the fan inlet and outlet (fig.6)

The straight air duct section length shall be equal to one air duct diameter at inlet and three air duct diameters at the outlet.

Avoid installing the filters or other equipment in the above air duct sections. To reduce vibration due to the fan operation install the fan onto the anti-vibrations rubber mounts. The airflow direction is to match the pointer direction on the fan casing.

Set the motor speed and the temperature threshold values by means of rotating the respective control knobs. The set temperature range is from +20°C to +30°C for the models equipped with TSC electronic module.

**PROHIBITED:**

Do not install the fan on the flammable material and do not mount it vertically to the wall by means of eyebolts.

Disconnect the fan from the power supply before conducting any works with the fan. The electrical connection are to be performed by a qualified electrician personnel. The rated electrical fan parameters are shown on the label. Any changes in the internal connection are prohibited and result in loss of warranty claim.

**WARNING**

The fans are designed for connecting to AC 220-240V, 50 Hz network.

Fans are designed for continuous operation with continuous power supply.

Depending upon the modification two connection options are available.

- through the terminal box (fig. 19-22, 24)

- through the power cord with the plug for R modification (fig. 25)

The fan shall be connected by means of the terminal block on the terminal box in compliance with the wiring diagram and terminal designation on the fig. 23.

The fan shall be connected through insulated durable copper wirings with the cross section not less 0.75 mm² and 1.00 mm² for KSD S 315-6E modification.

During selecting the wires consider the heating limit for the wires depending on the wiring type, wiring length and its layout peculiarities, i.e. Open cabling, cable channel or wall layout modification.

The fan shall be reliably grounded. The automatic circuit breaker incorporated into the fixed power network that breaks all the phases shall be installed at the external electric input (220V, 50Hz).

KSD fan shall be connected to the power network through the automatic circuit breaker with the clearance between the dead contacts not less than 3 mm for all poles.

QF automatic external circuit breaker shall be located in such a way as to enable the easy access for ON/OFF operation. The current protection value shall be selected depending on the fan current consumption.

The recommended rated current of the automatic circuit breaker is shown in the table 3. TSC electronic module modifications are equipped with the built-in temperature regulator and speed controller that operate depending on the air temperature, with incorporated or external temperature sensor.

**Fan connection
to the power
network**

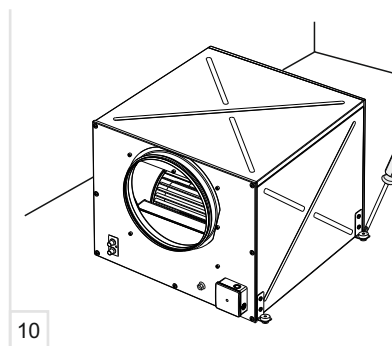
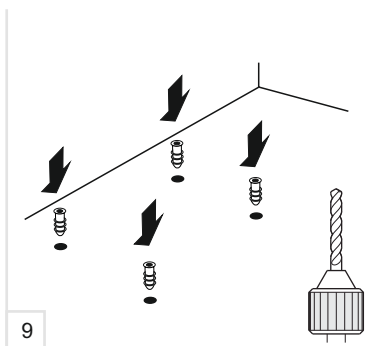
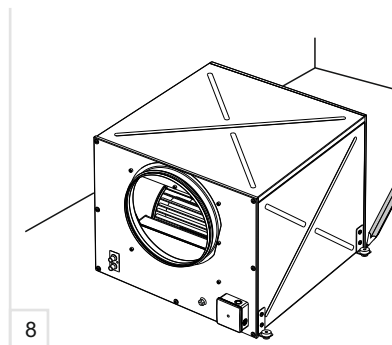
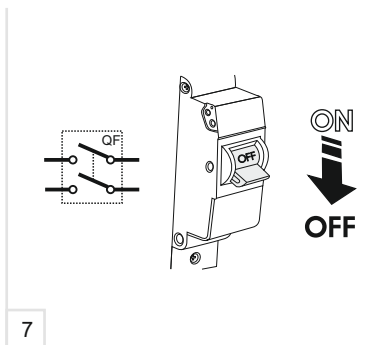

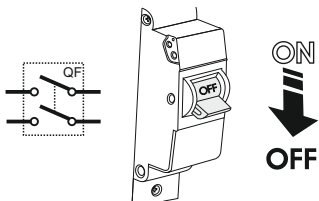

11

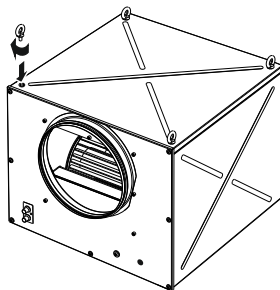

12

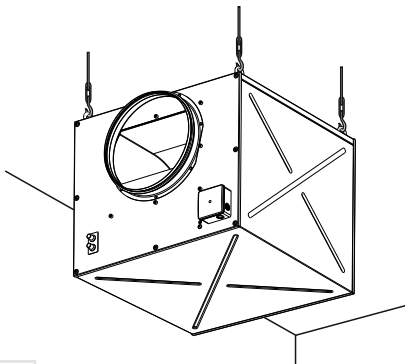

13

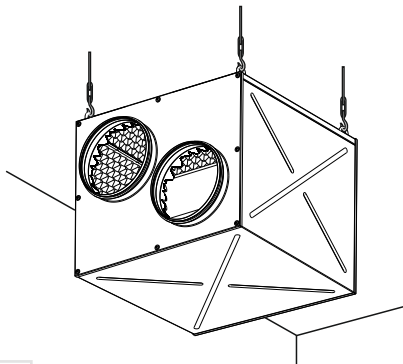

14

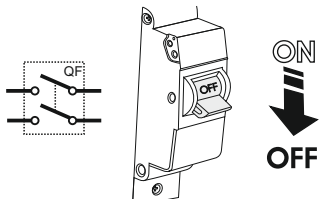

15

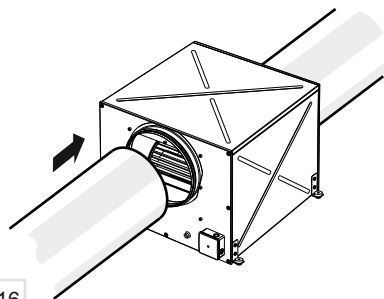

16

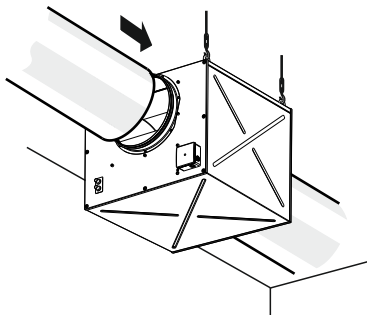

17

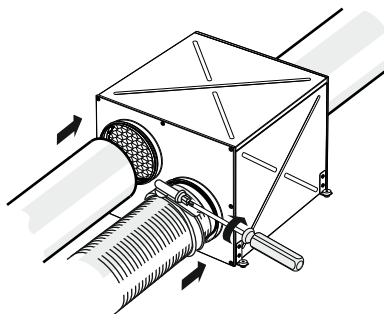

18

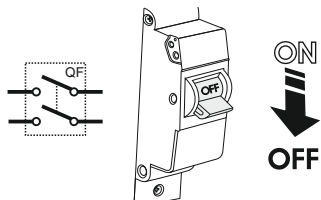

19

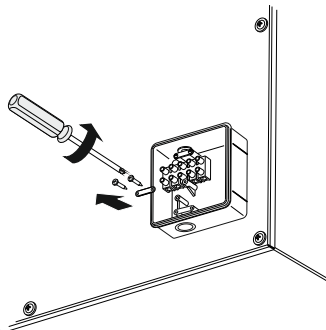

20

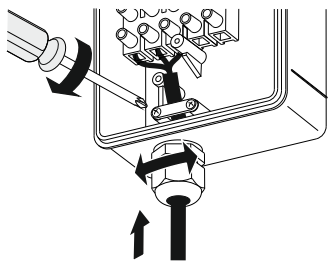

21

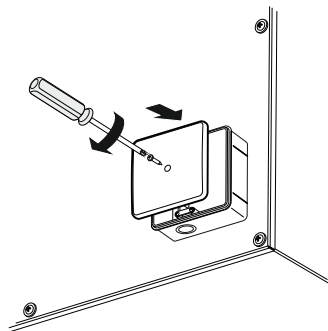

22

**Recommended rated overload current
for QF automatic circuit breaker**

Fan model	Recommended current, A
KSD 315-6E	4
KSD 315-4E	6,3
KSD S 315-4E	8
KSD S 315-6E	10
KSD 315/2x250-6E	4
KSD 315/2x250-4E	6,3
KSD S 315/2x250-4E	8
KSD S 315/2x250-6E	10

table 3

**WIRING
DIAGRAM**

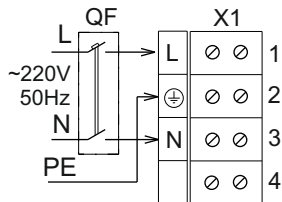

23

where
QF - automatic circuit breaker, available upon request;
X1 - terminal block

Electrical connection diagram for KSD fan with single-phase motor to AC network for modifications with terminal box.

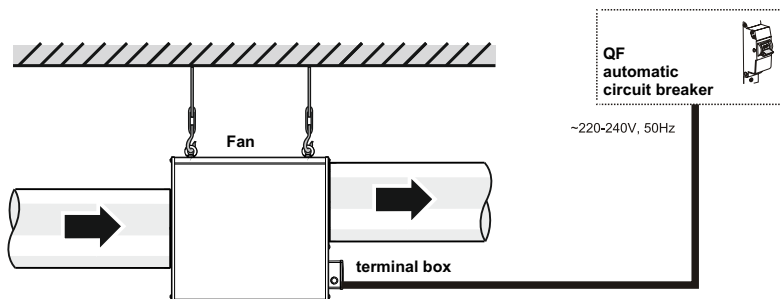

24

Connection of KSD fan with terminal box to AC network

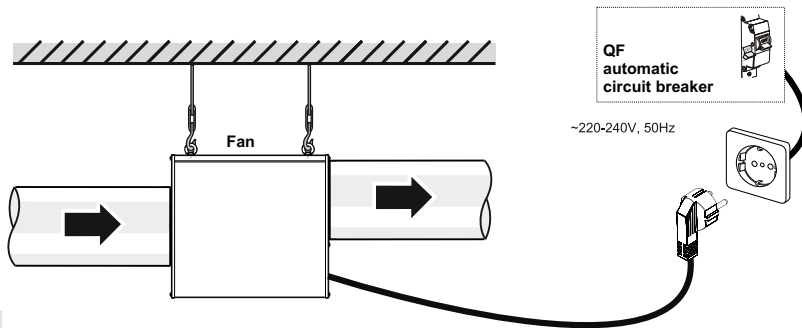

25

Connection of KSD fan with power cord and plug to AC network

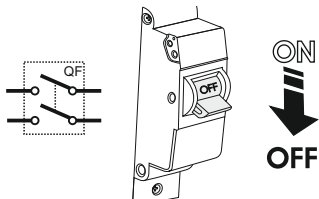

26

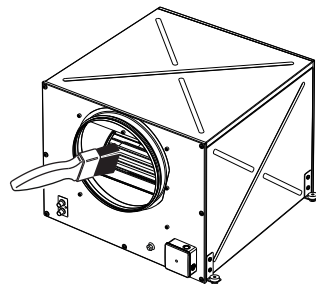

27

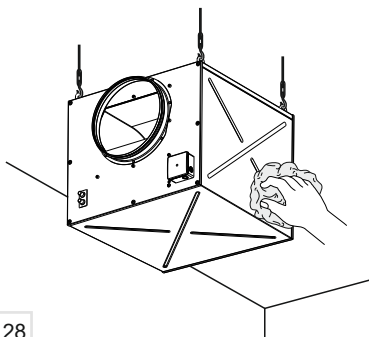

28

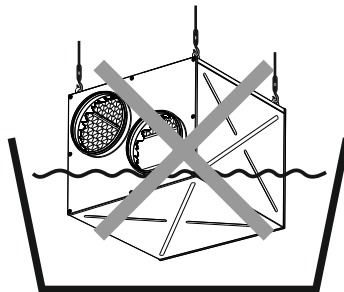

29

Any maintenance and repair works are to be executed after the fan disconnection from power supply network (fig. 26-29).

Maintenance means periodic clearing of the surfaces from dust and dirt. Use a dry soft brush or compressed air to remove dust from the metal parts of the fan.

Use a vacuum cleaner to remove dust from sound-insulated surface. The impeller blades should be thoroughly cleaned every 6 months.

Disconnect the air ducts from the fan. Clean the blades with detergent solution and avoid water dropping on the electric motor and inside the electromic module.

In case of any problems connected to the fan switching ON or its operation use a troubleshooting table to eliminate the faults (table 4).

Maintenance works of the fan are to be performed after disconnecting it from the network. Any maintenance works are prohibited when the fan is connected to the power supply.

Store the fan in manufacturer's packaging in ventilated room at the temperatures between +5°C and +40°C and relative humidity not more than 80% at +20°C. No aggressive impurities and other aggressive mixtures in the air are allowed.

Manufacturer guarantees rated performance of the unit within 24 months from the sale date through the retail network in accordance to the rules of transportation, storage, assembling and operation.

In case of no confirmation of the sales date the warranty period is calculated starting from the production date.

In case of failure due to faulty manufacturing during warranty period, the Consumer has the right to have it exchanged by the Seller.

Maintenance



PROHIBITED:

Storage regulations

Manufacturer's warranty

Problem	Possible reasons	Recommended remedy
The fan is not turn on	Wrong electrical connection. No power supply to the terminal block.	Using a multimeter instrument check the current supply on the terminal block. Disconnect the fan from power supply. Check the electrical connection reliability in the terminal block, circuit breaker and socket. Connect the fan following the wiring diagram.
	The motor speed is too low, the motor or the impeller blades become jammed	Turn the automatic circuit breaker off. Rotate the impeller manually and make sure of no foreign objects inside the impeller that disturb the imeller free rotation.
	Operating temperature of the air supplied to the fan is not sufficient to switch the electric speed module for the modes with TSC module	Control knob of speed control for TSC model is set to the minimum speed or off position (extreme left position of the control knob).
The automatic circuit breaker starts as the fan is switched on.	Increased current consumption due to short circuit in the electric circuit that results in switching the automatic circuit breaker on.	Switch the fan off. Exclude the reason of the increased current consumption. Check the automatic circuit breaker condition and automatic switch overload current value. Switch the automatic circuit breaker off and on. Switch the fan on again.
Low air capacity	The ventilation system elements as air diffuser, grilles, air ducts) are polluted. The fan components (impeller, flange) are polluted. The air ducts can be damaged, the grilles and/or diffusers can be closed.	Clean the ventilation system elements - diffusers, grilles, air ducts as well as the fan components - the impeller and the flange. Make sure that the air ducts are not damaged and that the diffusers and the air shutoff dampers are opened.
High noise and vibration level	The fan is polluted. The screw connections are loose.	Clean the fan. Check and tighten the screw connections.
	Faulty fan installation causes increased noise generation due to no anti-vibration elements or fan installation on metal surfaces.	Install the fan onto the anti-vibration rubber mounts which are available on a separate order. To do so fix the mounting brackets to the casing and connect the anti-vibration rubber mounts to the mounting brackets.
	Faulty fixation of the air ducts, the supply air duct is made of rigid metal.	Replace the rigid air ducts with the flexible ones. Tighten the fixing clamp screws with the force that excludes the air duct crank.

The manufacturer is not responsible for any damages resulting from the unit misuse or gross mechanical effect. The fan user should observe the user's manual.



Fan is recognized suitable for operation.

**ACCEPTANCE
CERTIFICATE**

KSD	<input type="text"/>	250	<input type="text"/>	-4E	<input type="text"/>	U	<input type="text"/>		
KSD S	<input type="text"/>	315	<input type="text"/>	-6E	<input type="text"/>	U1	<input type="text"/>	N	<input type="text"/>
		315 / 250*2	<input type="text"/>					R	<input type="text"/>

Stamp of the acceptance inspector

Date of issue

Sold by
(name of the vendor, stamp of the shop)

Date of sale

